

THIS DRAWING IS UNPUBLISHED. RELEASED FOR PUBLICATION, 19 .  
 © COPYRIGHT 19 BY AMP INCORPORATED. ALL INTERNATIONAL RIGHTS RESERVED.

LOC	DIST	P	F	REVISIONS			DATE	APPD
G	14			ZONE	LTR	DESCRIPTION		
					S	REV / 0L20-0195-97	22AUG97	ME TM

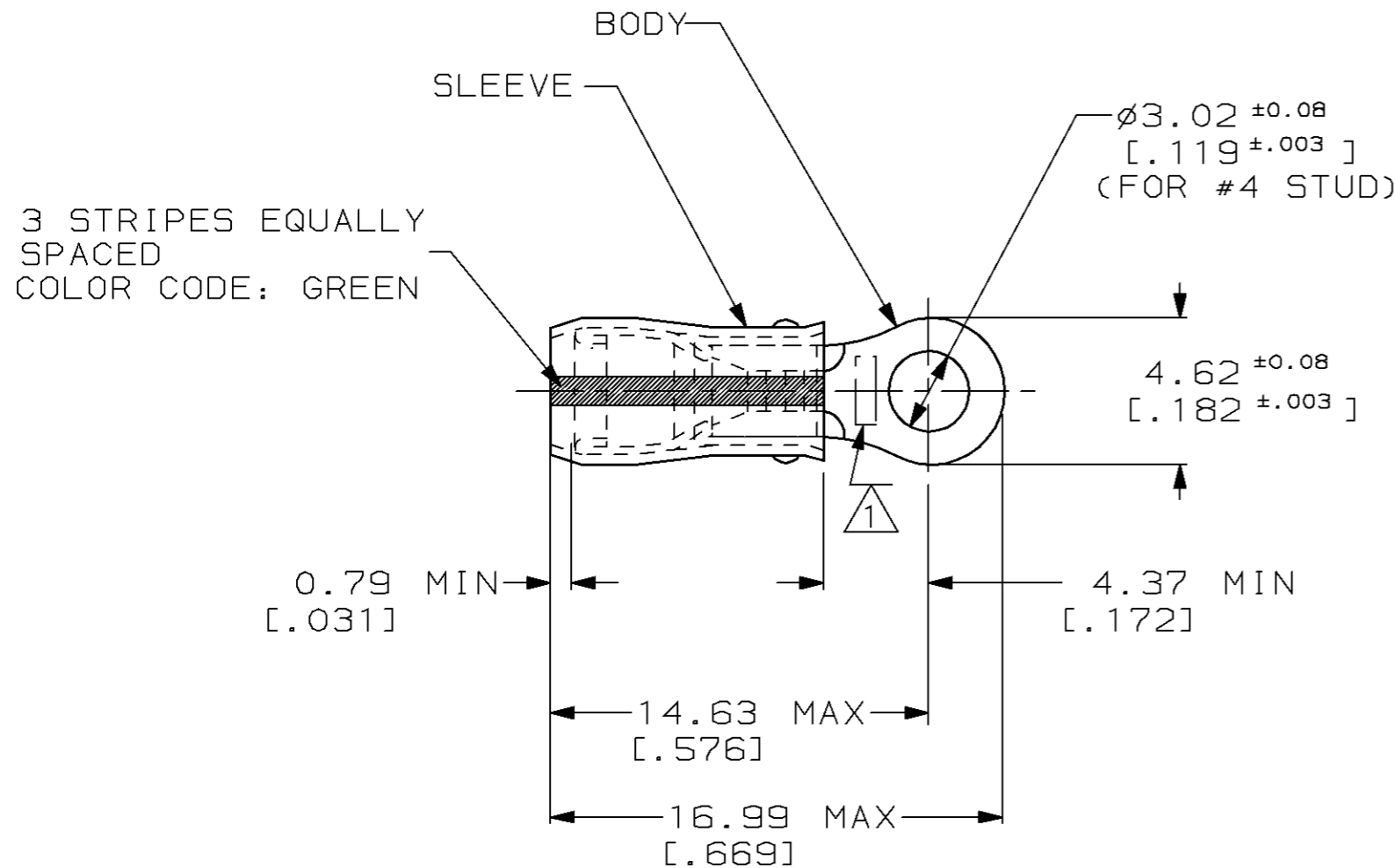

1 STAMP AMP APPROX AS SHOWN

- 2 WIRE INSULATION DIA, 2.03 - 3.18 [.080 - .125]
- 3 TONGUE MATERIAL THK, 0.79±0.05 [.031±.002]

AMP INCORPORATED CUSTOMER SERVICE SYSTEMS		MAX RECOMMENDED OPERATING TEMPERATURE: 105°C MAX		MILITARY P/N AND CLASS		QUANTITY	PACKAGE TYPE	PART NO
FOR ADDITIONAL PRODUCT INFORMATION OR COPIES OF DRAWINGS AND TECHNICAL DOCUMENTS		PRODUCT INFORMATION CENTER 1-800-522-6752		DO NOT SCALE PRINT, UNLESS SPECIFIED DIMENSIONS IN mm [INCHES] TOLERANCES ON: 2 PLC DEC ± 0.20 [.008] 3 PLC DEC ± - ANGLES ± -		100	LOOSE PIECE, BOX	8-327654-1
FOR APPLICATION TOOLING INFORMATION		TOOLING ASSISTANCE CENTER 1-800-722-1111		MATERIAL COPPER PER ASTM B-152 SLEEVE, RED NYLON		1000	LOOSE PIECE	327654
FOR ORDER ENTRY		1-800-526-5142		FINISH TIN PLATE PER MIL-T-10727				
		THIS DRAWING IS A CONTROLLED DOCUMENT FOR AMP INCORPORATED. IT IS SUBJECT TO CHANGE AND THE CONTROLLING ENGINEERING ORGANIZATION SHOULD BE CONTACTED FOR THE LATEST REVISION.		DR 9/30/93 OK SCHRUM CHK 9/30/93 RE HERSEY APPD 9/30/93 ML ELLIS APPD 9/30/93 M BARNABA PRODUCT SPEC UL 486A APPLICATION SPEC NOT AVAILABLE				
				NAME AMP Incorporated Harrisburg, PA 17105-3608				
				TERMINAL, RING TONGUE, PIDG™, WIRE SIZE, 22-16 AWG				
				SIZE B				
				CAGE CODE 00779				
				DRAWING NO C-327654				
				SCALE NTS				
				SHEET 1 OF 1				